

RadEye™ 8

Large Area X-Ray Sensor

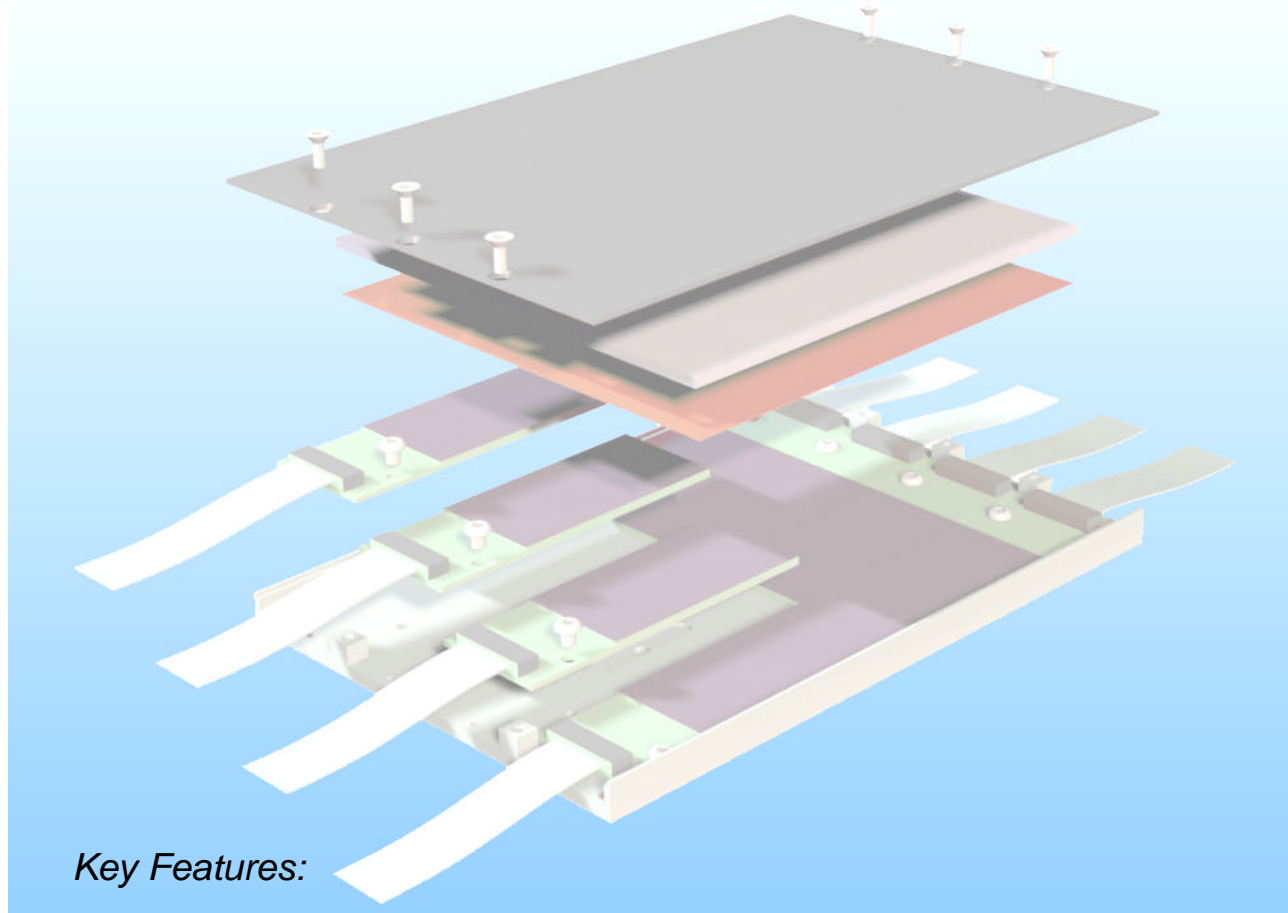

Key Features:

- Large 4" by 4" active area
- Over four million pixels
- 10 lp/mm resolution
- Dynamic range >10,000:1
- Variable frame rate (0.01 – 4.5 Hz)
- Eight parallel differential video outputs
- Fully integrated timing control
- Direct-coupled scintillator

The RadEye8 large-area x-ray image sensor extends the innovative tiling approach of Rad-icon's RadEye™ sensor series to a new dimension. The large 98.4 mm by 98.6 mm active area contains a 2048 by 2048 matrix of silicon photodiodes on 48 µm centers. Several timing modes allow for high flexibility in signal integration and readout. The RadEye8 is optimized to detect x-rays and other energetic radiation in the 10 keV to 50 keV range, making it an ideal choice for applications ranging from medical and scientific imaging to industrial inspection and non-destructive testing (NDT).

Description:

The *RadEye8* large-area image sensor contains eight individual *RadEye1* photodiode arrays along with their associated circuitry for scanning and readout. The eight arrays operate in parallel and can be driven with a single set of control lines. They are aligned and mounted in a 2x4 matrix on a common aluminum support base, resulting in a nearly seamless active area with a large 140 mm diagonal. The *RadEye8* module is packaged together with a scintillator in direct contact with the sensor, and a thin graphite window to protect the array. A secondary enclosure is required to completely shield the sensor from ambient light.

The support and control functions for the *RadEye8* sensor are integrated on-chip to minimize the amount of external circuitry needed to run the imager. Five digital control inputs determine the integration and readout timing. In *continuous* mode (*START=high*) only an external pixel clock is required to run the device. In *frame* mode (*START=pulsed*) the frame rate and integration time can be controlled externally. Adjusting the *START* frequency controls the integration time or synchronizes the imager to an external trigger such as the firing of an x-ray source (see timing diagrams on next page).

A *rising edge* on the *START* input triggers the beginning of each frame readout. *START* must return to a *low* level before the readout cycle ends. If *START* remains *high*, the next readout cycle begins immediately following the last line of the previous frame. The maximum *CLOCK* frequency is 2.5 MHz, which corresponds to a maximum frame rate of 4.5 frames per second (fps). In *continuous* mode, it is also possible to control the frame rate by adjusting the *CLOCK* frequency.

The *RadEye8* imager provides differential high-speed video signals from eight parallel video outputs. The dark level on each output lies approximately 1.8 V below the reference voltage *VD*. The positive video outputs (*OUTS*) are pulsed above the dark level for each pixel, whereas the negative video outputs (*OUTR*) are pulsed below. At saturation, the two outputs will swing approximately 0.7 V above and below the dark level. The conversion gain for the differential signal (*OUTS* – *OUTR*) is 0.5 μ V per electron.

Specifications:

Avg. dark current (at 23°C) ... 4000 electrons/sec*
Read noise (rms, at 1 fps) 150 electrons
Saturation..... 2,800,000 electrons
Dynamic range..... 85 dB (>14 bits)
Frame rate 0.01 to 4.5 fps
Max. data rate (each output)..... 2.5 MHz
Conversion gain 0.5 μ V/electron
Supply voltage (*VDD*) 5 V (\pm 0.25 V)
Supply current..... 8 x 25 mA (typ)
Reference voltage (*VD*) 3.8 V (\pm 0.5 V)
Analog output +..... 2 V (dark) to 2.7 V (sat)
Analog output –..... 2 V (dark) to 1.3 V (sat)
Digital “low” voltage..... 0.5 V max.
Digital “high” voltage 4.0 V min.
Operating temperature..... 0 to 50 °C
Storage temperature -25 to +85 °C
* dark current doubles approx. every 8°C

Connector Pinout:

Pin	Type	Signal	Description
1		VDD	Power (+5V)
2		GND	Ground
3	A	OUTS	Video Output +
4	A	OUTR	Video Output -
5		GND	Ground
6	A	VD	Reference In
7		GND	Ground
8	D	RESET	Array Reset In
9	D	START	Frame Start In
10	D	CLOCK	Master Clock In
11	D	BIN	Binning Select In
12	D	NDR	NDR Select In
13	D	FRAME	Frame Sync Out
14	D	LINE	Line Sync Out
15		GND	Ground

Type: A = Analog Signal D = Digital Signal

Timing Diagrams:

1. Continuous Mode (START is always high)

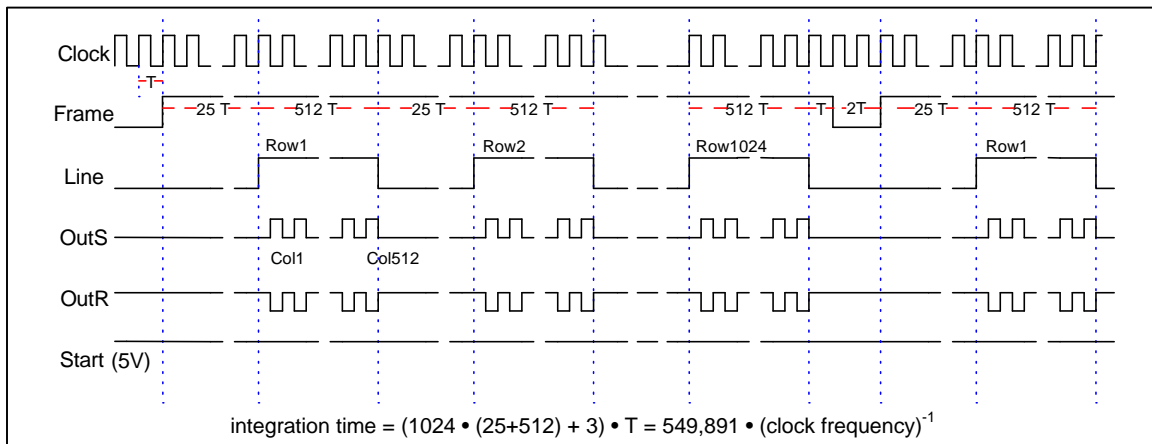

2. Frame Mode (START is pulsed)

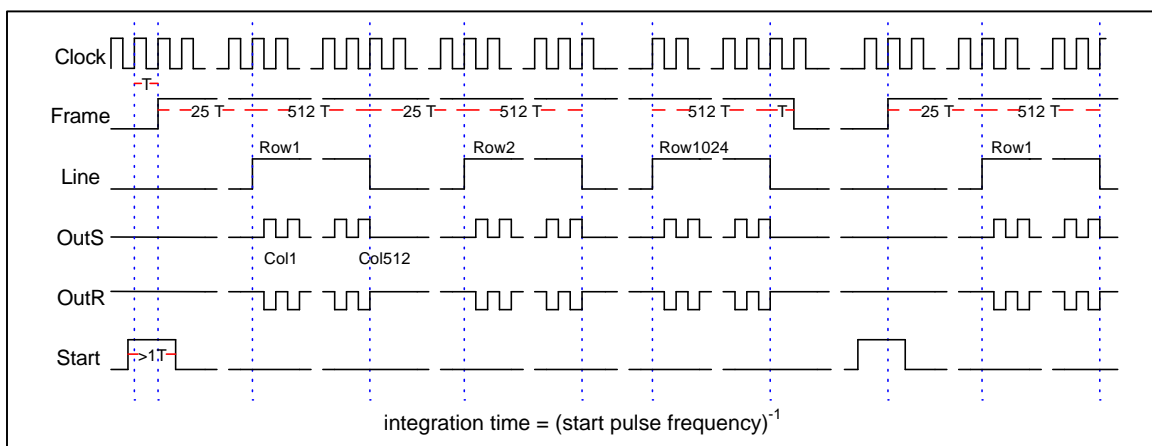

Additional Timing Modes:

The BIN and RESET inputs offer additional control over the readout functions. The BIN input, when *high*, causes the readout to skip every other row and column. This shortens the readout time and raises the maximum frame rate to 17.4 fps. A *high* level on the RESET input causes an asynchronous reset of all photodiodes in the active area. This feature can be used to reset the dark signal prior to an exposure.

The *RadEye8* also features a non-destructive readout (NDR) mode that is activated by setting the NDR input to a *high* level. In this mode, the voltage at each pixel is sampled without resetting the photodiode. This feature can be used to monitor the exposure level in the device, or to implement a low-noise readout mode by reading out and subtracting two images before and after an exposure. Both analog outputs carry the same signal when NDR is turned on. There is a slight increase in fixed-pattern noise when the NDR mode is activated, which can be compensated for by performing the appropriate offset correction in software. Please refer to *Rad-icon Application Note AN04* for more information on the *RadEye* sensor timing and using the NDR mode.

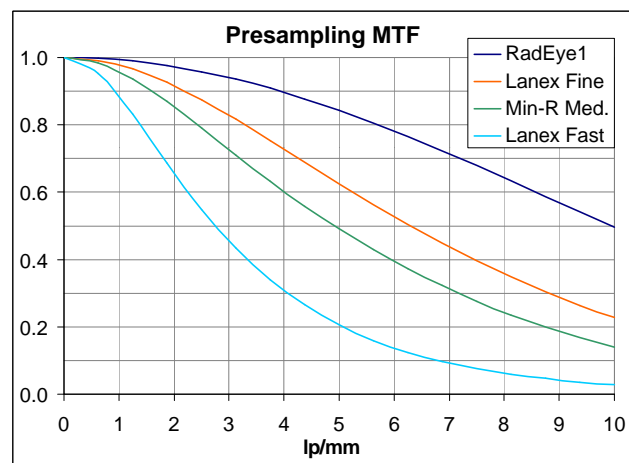

Detector resolution with various scintillators.

Mechanical Dimensions:

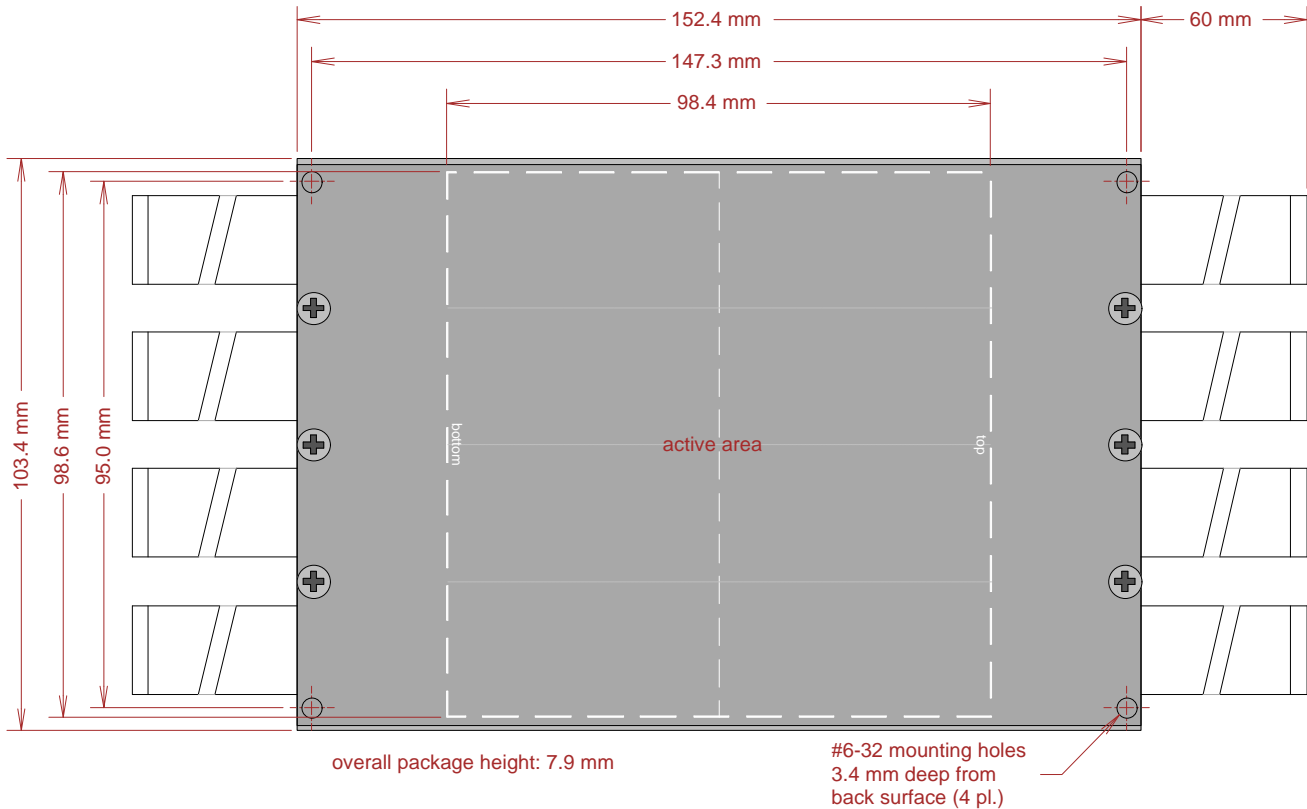

The *RadEye8* module contains eight individual *RadEye1* sensors that are mounted in a 2x4 mosaic and aligned to each other with sub-pixel accuracy. Small gaps between the individual sections of the active area are each approximately 2-3 pixels wide. Eight identical 15-pin flex cable connectors provide power and signal connections to the sensors. The *RadEye8* ships with a 2.5" long flex cable (Samtec P/N FJ-15-D-02.50-4) attached to each sensor. Except for the output signals from each sensor (pins 3, 4, 13 and 14) all pins among the eight cables can be connected in parallel.

A frame from the *RadEye8* imager consists of two back-to-back sections of 1024 lines of pixel data. Each line consists of 2048 pixels (512 pixels on each output). Since all eight sensors read out in parallel, two lines (one in each section of the sensor) will read out at the same time. The readout scan starts at the center of the image and proceeds towards the top and bottom edges. Each line in the bottom section scans as four 512-pixel segments reading left to right, whereas each line in the top section consists of four segments reading right to left.

Depending on the application, it may be possible to ignore the gaps between the eight image sections and simply merge them together. Another option is to interpolate the missing information across the gaps. Please refer to *Rad-icon Application Note AN03* for more detailed information regarding this topic.

Ordering Information:

Rad-icon P/N	Description
1080-01	Premium Grade ¹ , Min-R Medium Scintillator
1080-02	Standard Grade ² , Min-R Medium Scintillator
1080-03	Premium Grade, Lanex Fine Scintillator
1080-04	Standard Grade, Lanex Fine Scintillator

¹ no line defects ² up to 15 line defects

The standard *RadEye8* module is packaged with a Gd₂O₂S scintillator (Kodak Min-R Medium or Lanex Fine) and a 1 mm thick graphite window. Other scintillator and window options may be available on request.